

## OPERATOR COMFORT AND SAFETY FEATURES

- ◆ Cab mounted on three stage vibration damping mounts
- ◆ Cab climate control
- ◆ Specially designed parking brake system

## ADVANCED HYDRAULIC SYSTEM

- ◆ The closed loop hydraulic system has three filters for greater reliability.

## DRUM VIBRATION TECHNOLOGY

- ◆ The use of water wheel type lubrication on the vibratory bearing extends the bearing life up to 5,000 hours.
- ◆ Drum evenness and smoothness meets stringent highway surface work requirements.
- ◆ Road surface clearance height at the edge can be up to 825mm.

# STR30C-8 TANDEM DRUM ROLLER

## STR30C-8 双钢轮压路机



### 领先的振动轮技术

- ◆ 独创鼠袋式润滑装置充分润滑轴承，轴承使用寿命达 5000h 以上
- ◆ 高平整度、高密度度，满足高速路面施工严格要求
- ◆ 贴边压实接近间隙高度达到 825mm

### 灵动智能的操控系统

- ◆ 左右各 90° 旋转的操纵台，便于贴边压实
- ◆ 振动、行驶手柄一体化的操纵边箱，方便灵活

### 安全舒适的人性化设计

- ◆ ROPS 认证驾驶室，可有效保证驾驶员的生命安全
- ◆ 驾驶室三级减振和空调确保舒适的工作环境，司机耳边噪声在 80dB 以内
- ◆ 驾驶室减振效果达到良好级
- ◆ 设计驻车旋钮、紧停按钮保证施工安全

### 强劲的动力系统

- ◆ 动力强劲，适用坡道施工等各种工况
- ◆ 油路三级过滤
- ◆ 两侧开启发动机罩，各维修点触手可及

### 先进液压系统

- ◆ 闭式液压系统，效率高，可靠性高

### 可靠的洒水系统

- ◆ 800L 容积的两个滚塑水箱，一次加水可正常施工 5.7h 以上
- ◆ 有效避免钢轮粘沥青
- ◆ 备用的洒水泵设计，确保施工顺畅

## RELIABLE OIL-SPRAYING SYSTEM

- ◆ 800L plastic lined water tanks provide water for up to 5.7 continuous hours of work
- ◆ Optimized spray amount prevents asphalt from sticking to drums and limits asphalt cooling.
- ◆ A back-up spray pump for greater reliability

## RELIABLE AND EFFICIENT POWER

- ◆ Sufficient power to operate on slopes
- ◆ Three stage fuel filter system
- ◆ Engine cover opens wide to provide easy access for maintenance

## EFFICIENT CONTROL SYSTEM

- ◆ The operating controls can swing up to 90° right or left to allow the operator a clear view when working at the road edges.
- ◆ The speed and direction control joystick are integrated for greater control

# TECHNICAL PARAMETER 技术参数

## STR30C-8 双钢轮压路机技术参数

Technical Parameter of STR30C-8 Tandem Drum Roller

型号 Model		STR30C-8
质量载荷参数 Weight and Load	工作质量 Operating Weight(kg)	3000
	前轮分配质量 Weight at Drum(kg)	1450
	后轮分配质量 Weight at Rear axle	1550
	前轮静线载荷 Front Drum Static Liner Load(N/cm)	118
	后轮静线载荷 Rear Drum Static Liner Load(N/cm)	126
	振动频率 Vibration Frequency(Hz)	55/67
压实机构参数 Compaction	名义振幅 Nominal Amplitude(mm)	0.5
	激振力 Excitation Force(kN)	28/46
	振动轮直径 Drum Diameter(mm)	700
	振动轮宽度 Drum Width(mm)	1200
	钢轮厚度 Drum Edge Thickness(mm)	14
	行驶速度 Travel Speed(km/h)	0~11
机动性能参数 Maneuver Ability	工作速度 Working Speed(km/h)	0~6
	理论爬坡能力振动 Theoretical Gradeability Vibratory	30%
	理论爬坡能力不振动 Theoretical Gradeability Non-Vibratory	40%
	最小离地间隙 Ground Clearance(mm)	240
	轴距 Wheelbase(mm)	1700
	转向角度 Steering Angle(°)	±30
	摇摆角度 Swing Angle(°)	± 6
	最小转弯外直径 Min. Turning Outside Diameter(mm)	7050
	蟹行距离 Crab Distance(mm)	/
	供应商 Brand	YANMAR
型号 Model	3TNV88-BDTC	
冷却系统 Cooling System	Water Cooling	
排放标准 Emission	GB 20891-2014 STAGE III	
额定转速 Rate Speed(rpm)	3000(gross)	
功率 Rated Net Power(kW)	28.1	
容量参数 Capacity	蓄电池 Battery(V×Ah)	12×40
	水箱 Water Tank(L)	160
	燃油箱 Fuel Tank(L)	40
	液压油箱 Hydraulic Oil Tank(L)	28

## 双钢轮压路机 STR30C-8 标配选配表

Tandem Drum Roller STR30C-8 Standard and Optional Configurations

配置类型 Config	配置名称 Systems	物料名称 Description	数量 / 台 Quantity	详细说明 Details	备注 Remarks
标准配置 Standard Configuration	主机 Main Machine	STR30C-8 双钢轮压路机标配  STR30C-8 Tandem Drum Roller, Standard	1	1.Engine 发动机 2.Travel Pump 行驶泵 3.Vibration Pump 振动泵 4.Travel Motor 行驶马达 5.Vibration Motor 振动马达 6.Reduction Gears 减速机 7.Operating Platform 操作平台 8.Electrical System 电气系统 9.Vibratory Drum (Smooth) 振动轮 10.Front Frame 前车架 11.Rear Frame 后车架 12.Water-Spraying System 洒水系统 13.Covering Parts 覆盖件 14.Seat 座椅	
可选配置 Optional Configuration	Shed (without HVAC) 驾驶棚 (无空调)	Shed (without HVAC) 驾驶棚 (无空调)	1	Low cost 低成本	选配替代操纵平台 Substitute operating platform allowed

## 双钢轮压路机 STR30C-8 尺寸参数

Dimensions of STR30C-8 Tandem Drum Roller

主要尺寸 Size Code	STR30C-8
A (mm)	1700
B (mm)	1280
C (mm)	550
D (mm)	700
H (mm)	/
H2 (mm)	2560
K (mm)	240
L (mm)	2550
O (mm)	40
W (mm)	1200

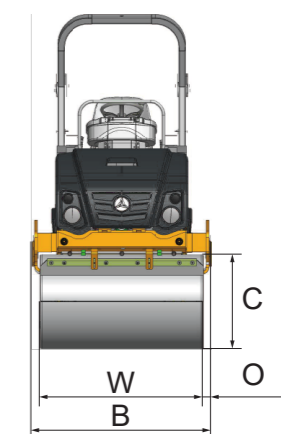
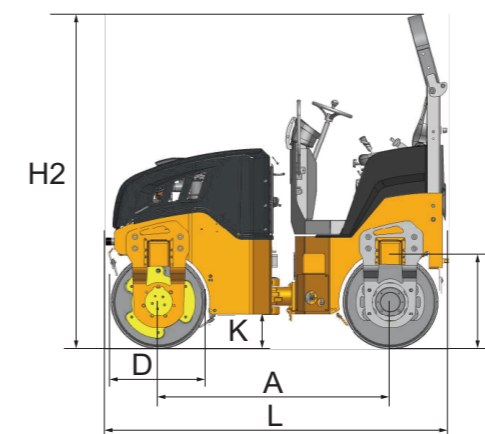

SANY HEAVY INDUSTRY CO., LTD.

SANY Industry Town, Changsha Economic and Technological Development Zone,  
Hunan Province, China

Service Line: +86 4006 098 318 E-mail: crd@sany.com.cn

**SANY**<sup>®</sup>  
QUALITY CHANGES THE WORLD.