

o Standard Configuration

Engine

- G, S and B mode control
- 24V starter motor
- 30A alternator
- Air prefilter
- Dry type dual-element air filter
- Cylinder-type engine oil filter
- Cylinder-type fuel oil fine filter
- Fuel oil coarse filter
- Radiator with protective screening
- Radiator auxiliary water tank
- Fan aerofoil
- Isolated mounted engine
- Automatic idling system

Hydraulic system

- Control valve with main overflow valve
- Spare oil port of control valve
- Oil suction filter
- Return oil filter
- Pilot filter

Slewing platform of superstructure

- Fuel oil level sensor
- Hydraulic oil level gauge
- Tool kit
- Slewing parking brake
- Grease bucket holder
- Counter weight

Alarm system

- Engine oil pressure too low
- Fuel oil level too low
- Coolant temperature too high
- Air filter restriction
- Engine racing
- Voltage too low
- Voltage too high

Cab

- Sound-proof steel-structure cab
- Reinforced light-color glass window
- 4 silicone oil rubber damper supports
- Openable front wall upper window and left side window
- Emergency exit on rear window
- Wiper with washer
- Adjustable tilting seat with adjustable armrest
- AM-FM radio with digital clock
- Foot rest and floor mat
- Loudspeaker
- Seat belt and fire extinguisher
- Cup holder and reading lamp
- Ashtray and escape hammer
- Cigar lighter
- Pilot controlled cut-off lever

Air conditioning system

- Dual-purpose air conditioner

Instruments of monitoring system

- Liquid crystal control monitor
- Failure diagnosis and alarm system
- Hour meter and fuel tank oil level gauge
- Engine coolant temperature

Traveling body of undercarriage

- Traveling parking brake
- Traveling motor guard plate
- Grease filler cover plate on traveling beam
- Hydraulic tensioning device of tracks
- Bolted driving wheel
- Thrust wheel and carrier wheel
- Reinforced chain trail
- 400mm triple bulging track shoes
- Bottom cover plate

Front-end working device

- Flange pin
- Welded connecting rod
- All bucket pins are equipped with dustproof seal ring
- All-welded box-type boom
- All-welded box-type bucket rod

Others

- Dual battery
- Lockable front/rear engine hoods
- Lockable fuel oil filler cap
- Left/right armrest box
- Traveling direction sign on traveling carriage
- Working lamp



- Rated power
36kW/2100rpm
- Total weight
5780kg
- Bucket capacity
0.21-0.25(0.23 m³)

SY55C

Fully upgraded new-generation excavator

Brand new change

QUALITY CHANGES THE WORLD

Lead by Innovation Splendid SANY



Shanghai SANY Heavy Machinery Co., Ltd.

www.sany.com.cn

Shanghai SANY Heavy Machinery Industrial Park, Ping'an Town, Fengxian District, Shanghai City, China

Note

This is a sample and is only for reference. All configuration shall be subject to the contract or material object, and may be changed without further notice; All Rights Reserved! No contents in the sample shall be duplicated or copied for any purposes without written approval of SANY Heavy Machinery.

© Printed in China
No.: ZJSYX0604CH (March 2016)

SY55C

Energy Efficiency Value Leader

New-generation SY55C Hydraulic Excavator



Selling Points

SY55C is a star product of mini-excavator of SANY and ranks the first place in market share of single model in 4 continuous years. Accumulative sales amount over ten thousand units. New-generation SY55C hydraulic excavator features "high reliability, excellent performance, safe & environmental-friendly and comfortable & convenient".

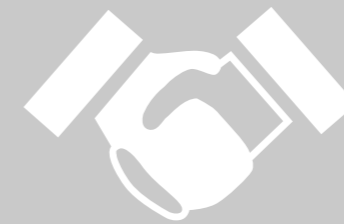

High reliability



Excellent performance



Safe & environmental-friendly



Comfortable & convenient

High reliability

o Highest reliability in the industry

Reliability

- SY55C is improved on aspects of structural member reinforcement and low failure rate etc. Overall reliability leads in the industry.



o Top-ranking core configuration

Core configuration

- Isuzu engine meeting emission standard national III exclusively for SANY could ensure the operating reliability of the machine under severe conditions.
- Rexroth main pump, Rexroth main valve and hydraulic components from world famous brands ensure high reliability of hydraulic system.
- Reinforced structural members with brand-new design have longer service life.
- The total weight is much larger than that of other companies and the stability is higher.



Engine



Hydraulic pump



Traveling motor



Slewing motor



Multitandem valve

o More powerful energy

Power system

- Ultra-light power engine exclusively for SANY: Power margin is sufficient, and service life is extended by over 10%.
- New-type parallel radiator: Coolant temperature is 3-5°C lower than the competitor and hydraulic oil temperature is 7-10°C lower than the competitor.
- External-mounting fuel filter: It has high capacity and strong assimilative capacity, and is equipped with ultra-large capacity dual oil-water separator.
- Air prefilter + dual air filter element could ensure sufficient and clean air and reduce the wear of cylinder components.



Standard configuration prefilter



Dual air filter element



External-mounting fuel filter



Ultra-large parallel radiator

o Durable structural members

Boom

- Rear support and center support of the boom adopt forgings for avoiding concentrated local welding stress and improving the durability.
- Key positions are enveloped with fortified steel plate for severe working conditions.



Arm

- Rear support is made of forgings for avoiding concentrated local welding stress and improving the reliability.
- With wear-resisting plate on front end, the service life of bucket rod is extended.



Bucket

- It is reinforced bucket for rocks and is fitted with wear-resisting steel plate at the bottom so that the strength of bucket is improved.
- With secondary arc shape of optimized design, the digging resistance and the wear of sand and rock against the bucket body when digging so that it saves energy and is more durable.

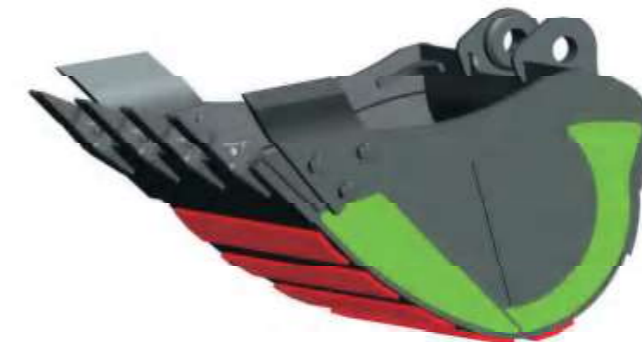

o Durable structural members

Platform

- High-strength slewing platform .
- D-shaped large-section side beams are more secure, can survive higher external impact and improves the decorous feeling of complete machine.

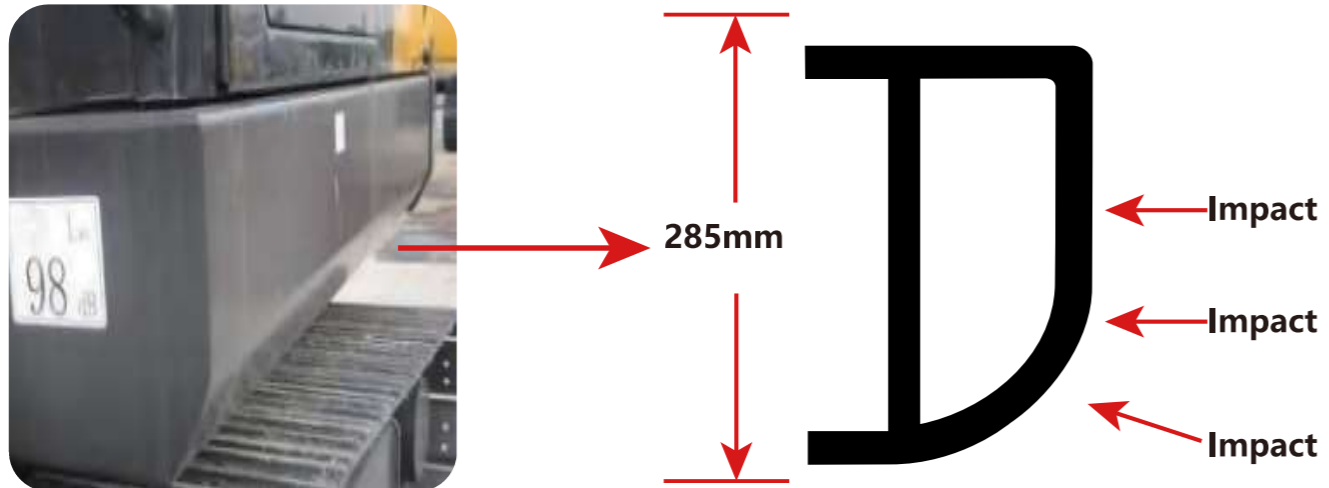

Structural analysis

- Through professional CAE analysis, optimize the structure and reduce stress concentration; consequently mean service life of working device is extended by 30%.



o Efficient and energy saving hydraulic system

Undercarriage

- Complete hydraulic buffer system minimizes the internal impact of hydraulic system .
- With performance test of 30,000 times and market verification of 50,000 units, the operating stability of complete machine is improved and product life is extended significantly.



o Complete research, development and test system

Test system

- Complete research, development and test system is the strong backup for excellent performance.
- It has established complete machine endurance test center with full functions. Each model of excavator must be subjected to over 2,000h field excavating test.
- Important parts and components like working device, cab and hydraulic components etc. must be subject to fatigue test over 800,000 times.



o Leading manufacturing technology

Manufacturing technology

- Leading manufacturing technology is a reliable guarantee for producing excellent products.
- SANY has RGV assembling line and full-automatic welding robots, and possesses high-precision machining equipment and precise machining center.
- SANY's manufacturing and assembling lines won five-star national site in 2013 and national quality award in 2014.



Excellent performance

More powerful

Engine

- Energy-saving environmental-friendly engine exclusively for SANY.

Isuzu engine
exclusively for SANY



Advantages of Isuzu engines:

- Energy-saving environmental-friendly engines exclusively for SANY are widely used and well recognized by the customers.
- It is sturdy, durable and fuel-saving, is fitted with low-cost spare parts and is convenient for maintenance. It should be the first choice for the excavator.

Higher efficiency

Efficiency Wins

- Brand new intelligent dual-core controller.
- Perfect matching of engine and hydraulic pump.

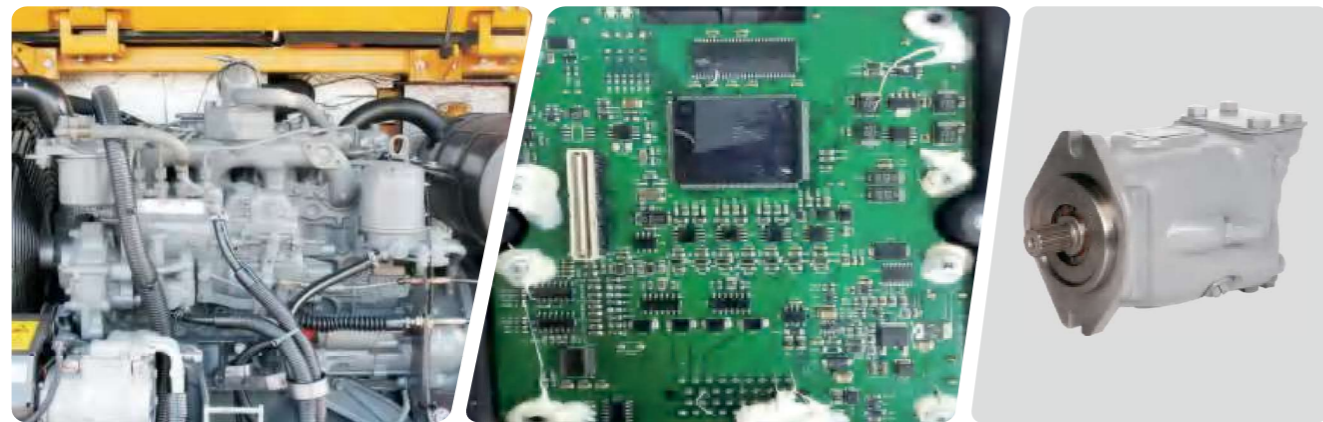

More perfect operation

Load-sensitive

- SANY utilizes load-sensitive system which features higher operating efficiency, better control performance, excellent leveling capacity and outstanding microoperation performance and is capable of providing almost perfect operating feeling.

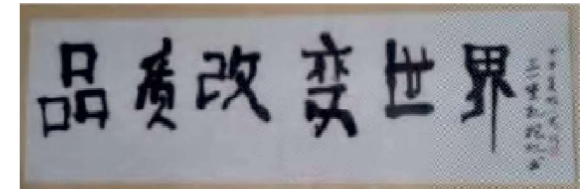

Calligraphy work by SY55C

Advantages of load-sensitive system:
Think what you desire, just like your hands!

Higher digging force

Stronger

- With more force than the competitor product of same tonnage, it is easier to excavate hard pan and makes excavation easier.



Safe and environmental-friendly

o Safety configuration of national standard

Safety certification

- Meet safety standard of many regions including China, EU and North America etc.
- SY55C cab adopts roll-over protective and fall-objects protective structural design and is certified with ROPS and FOPS.



Safety facility

- Wide view
- Fire extinguisher, escape hammer, break-in area and seat belt
- Dual front headlamps
- Compressor belt shield



o Environmental protection standard in world front

Recoverable

- All-metal covering part is used, is recoverable and environmental-friendly; the materials liable to pollution like glass fiber reinforced plastics are not used.

SY55C
All-metal covering parts are used



Environmental protection

- Environment engine is equipped and meets latest standard.
- Aluminum radiator and oil cooler are used.
- Environmental paint is used to minimize environmental pollution.
- Garden-type manufacturing site.



Comfortable and convenient

o Comfortable Driving • Warm like Home

Comfortable experience

- With high-grade trim parts, wide view, suspended seat, excellent vibration damping and noise reduction performance, the driving experience will be more comfortable.
- Dual-purpose air conditioner outputs air in stereoscopic mode and makes inside climate more comfortable.
- Cigar lighter, ashtray, cup holder and reading lamp all are complete.



o Maintenance • Within Easy Reach

Convenient maintenance

- Large-area covering part is used. After it is opened, daily maintenance can be carried out on the ground; thus the maintenance is convenient and the accessibility is good.
- Air filter, fuel oil coarse filter, fuel oil fine filter, engine oil filter and pilot filter element are within easy reach and can be maintained very conveniently.
- The beautiful and elegant grease bucket holder may be used to carry the grease bucket easily.
- Large-size tool kit may contain maintenance tools conveniently.
- Detachable radiator dust screen is convenient to be washed.



o Technical specifications

Specifications	
Total weight	5780kg
Bucket capacity	0.21-0.28(0.23m ³)

Engine	
Model	4JG1
Type	4-cylinder 4-stroke, direct injection, overhead valve in-line; water-cooled
Rated power	36kW/2100rpm
Maximum torque	175Nm/1800rpm
Displacement	3.059L

Capacity of oil and coolant	
Fuel tank	130L
Hydraulic oil tank	85L
Engine oil	9.6L
Radiator	6.5L
Final drive	2×0.9L

Main performance	
Traveling speed (high/low)	3.7/2.5 (km/h)
Slewing speed	10 rpm
Gradeability	70% (35°)
Ground pressure	32.75kPa
Digging force of bucket	45kN
Digging force of arm	33kN

Traveling section	
Number of track shoes	40
Carrier wheel on each side	1
Thrust wheel on each side	5
Standard track	400mm

o Overall dimensions (mm)

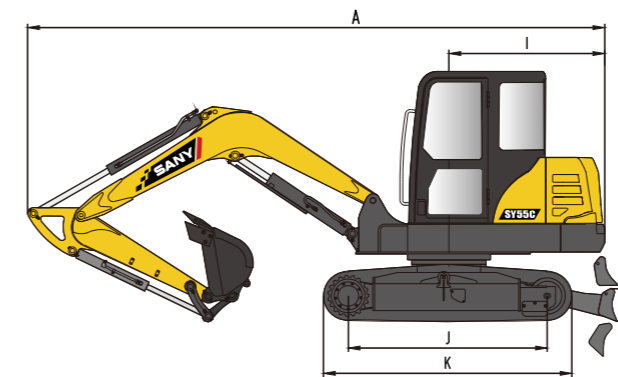
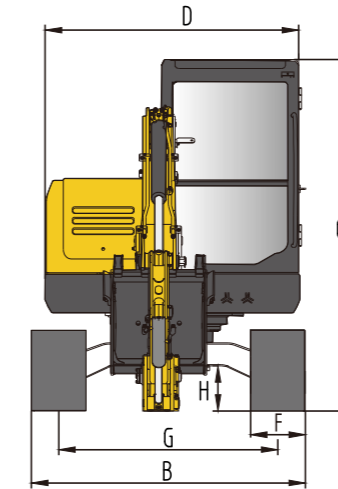

Overall dimensions	(Unit: mm)
A. Overall length (in transportation state)	5925
B. Overall width (in transportation state /in operation state)	2005
C. Overall height (in transportation state)	2595
D. Upper width	1860
E. Height of bulldozing plate	340
F. Width of standard track shoe	400
G. Track gauge (in transportation state / in operation state)	1600
H. Minimum ground clearance	330
I. Slewing radius of tail	1640
J. Wheel track	2045
K. Track shoe length	2545

Performance Parameters	
Total weight, kg	5780
Bucket capacity, m ³	0.21-0.25(0.23m ³)
Rated power, kW/rpm	36/2100
Traveling speed (high/low), km/h	3.7/2.5
Slewing speed rpm	10
Gradeability	70%/35°
Ground pressure, kPa	32.75
Digging force of bucket, kN	45
Digging force of bucket rod, kN	33

o Table of Lifting Capacity

Boom---	3000mm	Arm--	1550mm	Track---	400mm	Counter weight---	316kg	Radius of loading point (A)				Maximum distance	
Height of loading point (B) m		2.0m		3.0m		4.0m		5.0m		Loading capacity		Distance	m
		Longitudinal	Transverse	Longitudinal	Transverse	Longitudinal	Transverse	Longitudinal	Transverse	Longitudinal	Transverse		
4m	kg					*1100	*1100			*1150	1050	4.19	
3m	kg					*1150	1100			*1200	850	4.8	
2m	kg			*1800	1600	*1400	1050	*1250	750	*1250	750	5.11	
1m	kg			*2400	1500	*1650	1000	*1350	750	*1300	700	5.17	
0m	kg			*2650	1400	*1800	1000	*1400	750	*1400	750	5.0	
-1m	kg	*3750	2650	*2600	1400	*1800	950			*1500	800	4.57	
-2m	kg	*3550	2700	*2200	1450					*1600	1050	3.77	

1. The lifting capacity is calculated in accordance with ISO10560 and SAEJ1097, where limit coefficient of hydraulic system is 0.87 and tilting limit coefficient is 0.75;

2. The item with the mark * is limited by hydraulic pressure and the item without the mark "*" is limited by stability;

3. Lifting point is front support hole of bucket rod (excluding the weight of bucket). It is necessary to deduct from the above lifting capacity if additional accessory is installed such as bucket etc.

o Operating range (mm)

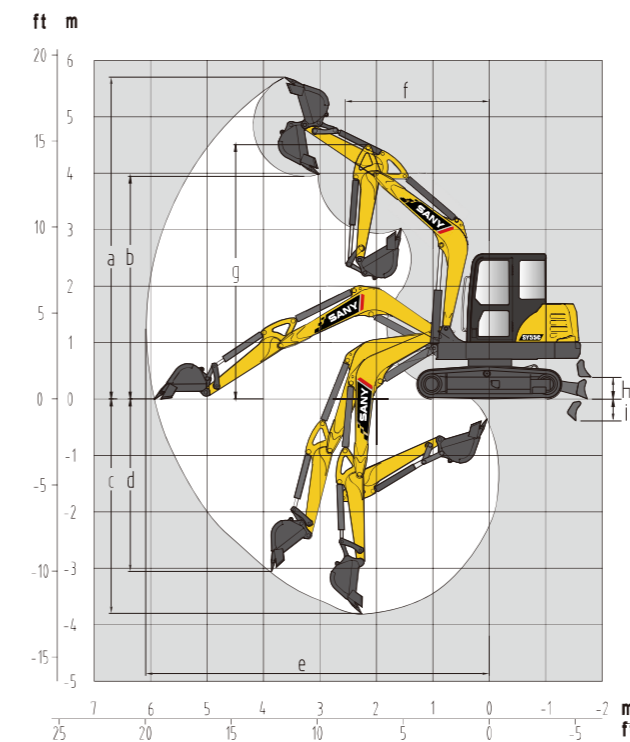

Operating range	(Unit: mm)
a Maximum digging height	5690
b Maximum unloading height	3930
c Maximum digging depth	3815
d Maximum digging depth with vertical boom	3070
e Maximum digging distance	6090
f Maximum slewing radius	2555
g Maximum height at maximum slewing radius	4495
h Maximum ground clearance with bulldozing plate lifted up	435
i Maximum cutting depth of bulldozing plate	420



Energy Efficiency Value Leader

SY55C

SY55C New-generation Hydraulic Excavator

